

# CILINDRU HIDRAULIC CU PLUNJER HYDRAULIC CYLINDER WITH PLUNGER

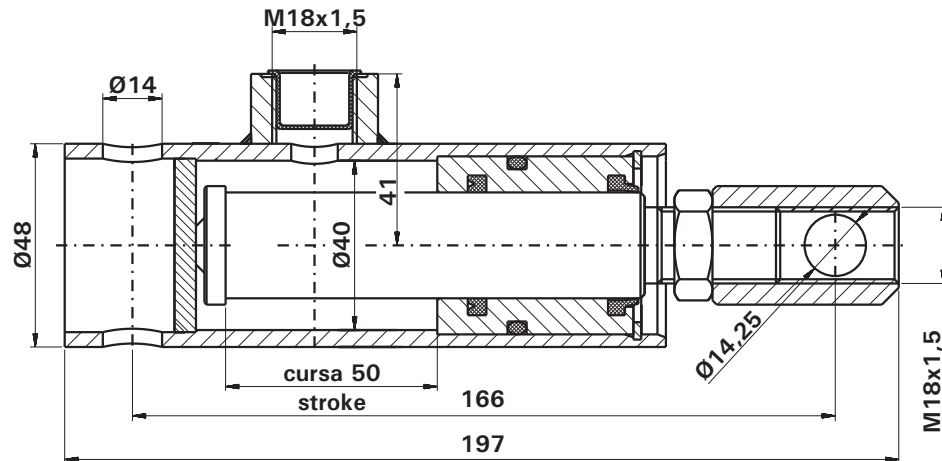

COD CLINDRU: C12-40.54.00 AM  
CYLINDER CODE

## CARACTERISTICI TEHNICE

- Presiunea nominală .....200 bar
- Presiunea maximă admisibilă .....230 bar
- Viteza de lucru .....max. 0,5 m/s

## SPECIFICATIONS

- Nominal pressure .....200 bar
- Max. admitted pressure .....230 bar
- Working speed .....max. 0.5 m/s

# CILINDRU HIDRAULIC CU PLUNJER HYDRAULIC CYLINDER WITH PLUNGER

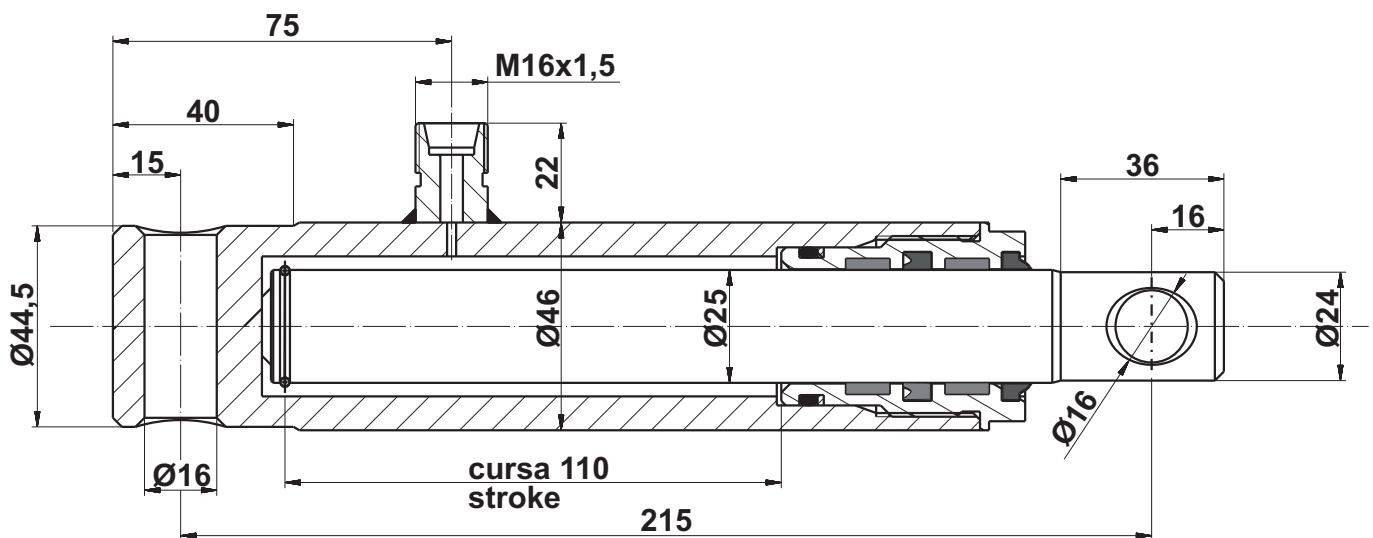

COD CLINDRU: CHPS25-110.0  
CYLINDER CODE

## CARACTERISTICI TEHNICE

- Presiunea nominală .....175 bar
- Presiunea maximă admisibilă ....250 bar
- Viteza de lucru.....max. 0,5 m/s

## SPECIFICATIONS

- Nominal pressure .....175 bar
- Max. admitted pressure .....250 bar
- Working speed.....max. 0.5 m/s

## CILINDRU HIDRAULIC CU PLUNJER HYDRAULIC CYLINDER WITH PLUNGER

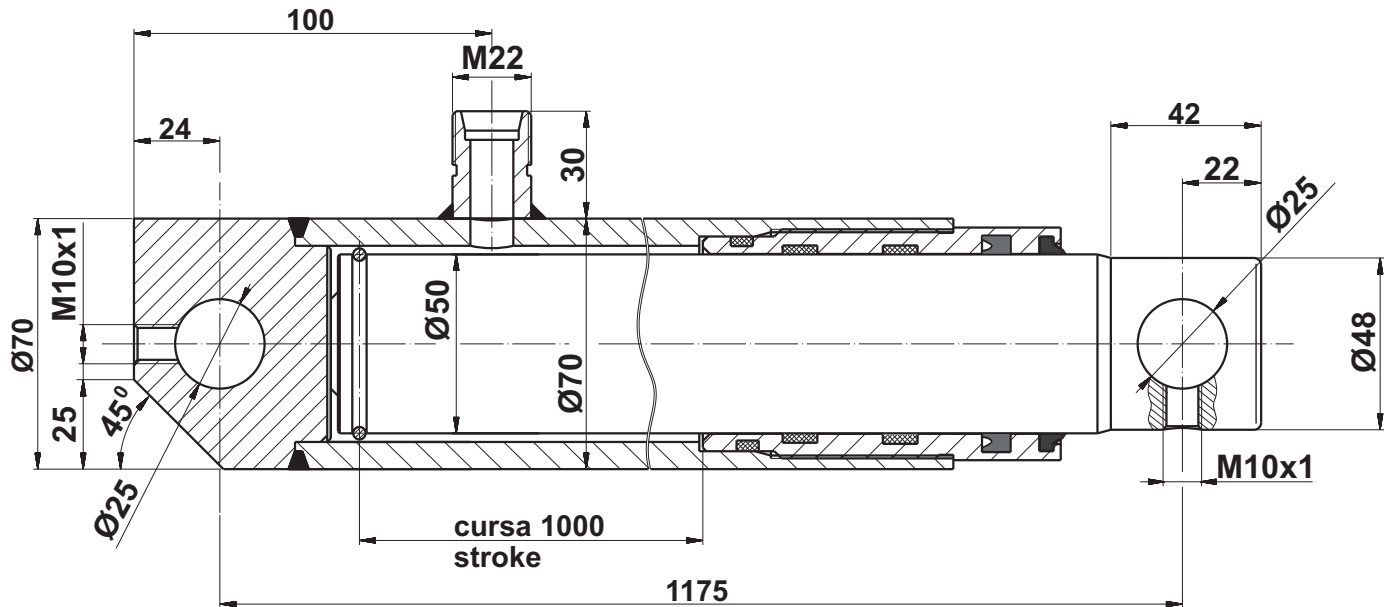

COD CLINDRU: CHPS50-1000.0  
CYLINDER CODE

### CARACTERISTICI TEHNICE

- Presiunea nominală .....175 bar
- Presiunea maximă admisibilă ....250 bar
- Viteza de lucru.....max. 0,5 m/s

### SPECIFICATIONS

- Nominal pressure .....175 bar
- Max. admitted pressure .....250 bar
- Working speed .....max. 0.5 m/s

# CILINDRI HIDRAULICI CU PLUNJER TIP CHPG

## HYDRAULIC CYLINDER WITH PLUNGER TYPE CHPG

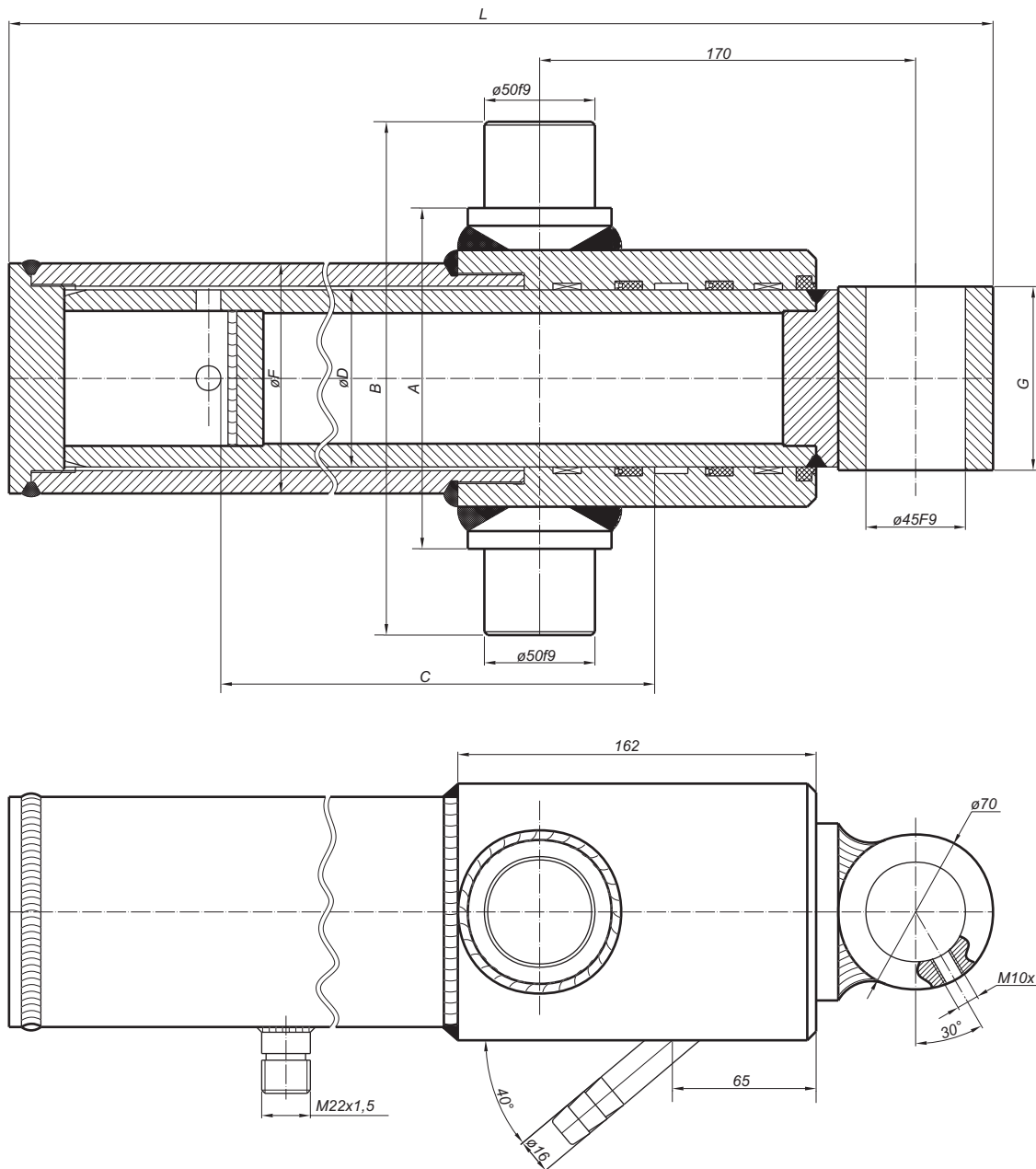
**CARACTERISTICI TEHNICE**

- Presiunea nominală ..... 150 bar
- Presiunea de deplasare a plunjerului fără sarcină ..... max. 10 bar
- Presiunea maximă admisibilă ..... 200 bar
- Viteza de lucru ..... max. 0,5 m/s

**SPECIFICATIONS**

- Working pressure ..... 150 bar
- Plunger moving pressure without load ..... max. 10 bar
- Max. admitted pressure ..... 200 bar
- Working speed ..... max. 0.5 m/s

**CILINDRI HIDRAULICI CU SIMPLU EFECT TIP CHPG**  
**(single effect hydraulic cylinders type CHPG)**

<b>Cod cilindru (Cylinder code)</b>	<b>L</b>	<b>D</b>	<b>F</b>	<b>A</b>	<b>B</b>	<b>G</b>	<b>C2</b>
CHPG80-950	950	80	104	154	232	83	702
CHPG80-1000.00	1000	80	104	154	232	83	752
CHPG80-1050.00	1050	80	104	154	232	83	802
CHPG90-1150.00	1150	90	114	154	232	93	902
CHPG90-1200.00	1200	90	114	154	232	93	952
CHPG90-1250.00	1250	90	114	154	232	93	1002
CHPG100-1150.00	1150	100	124	169	242	103	902
CHPG100-1200.00	1200	100	124	164	242	103	952
CHPG100-1250.00	1250	100	124	164	242	103	1002
CHPG100-1300.00	1300	100	124	164	242	103	1052
CHPG100-1350.00	1350	100	124	164	242	103	1102
CHPG110-1250.00	1250	110	134	174	252	113	1002
CHPG110-1300.00	1300	110	134	174	252	113	1052